

Liaisons mécaniques

.I Vé Réglable

I-1 Fonction :

Le Vé réglable est un mécanisme simple composé de 5 pièces dont la fonction globale est : positionner verticalement des pièces cylindriques en vue de les contrôler

I-2 Dessin d'ensemble

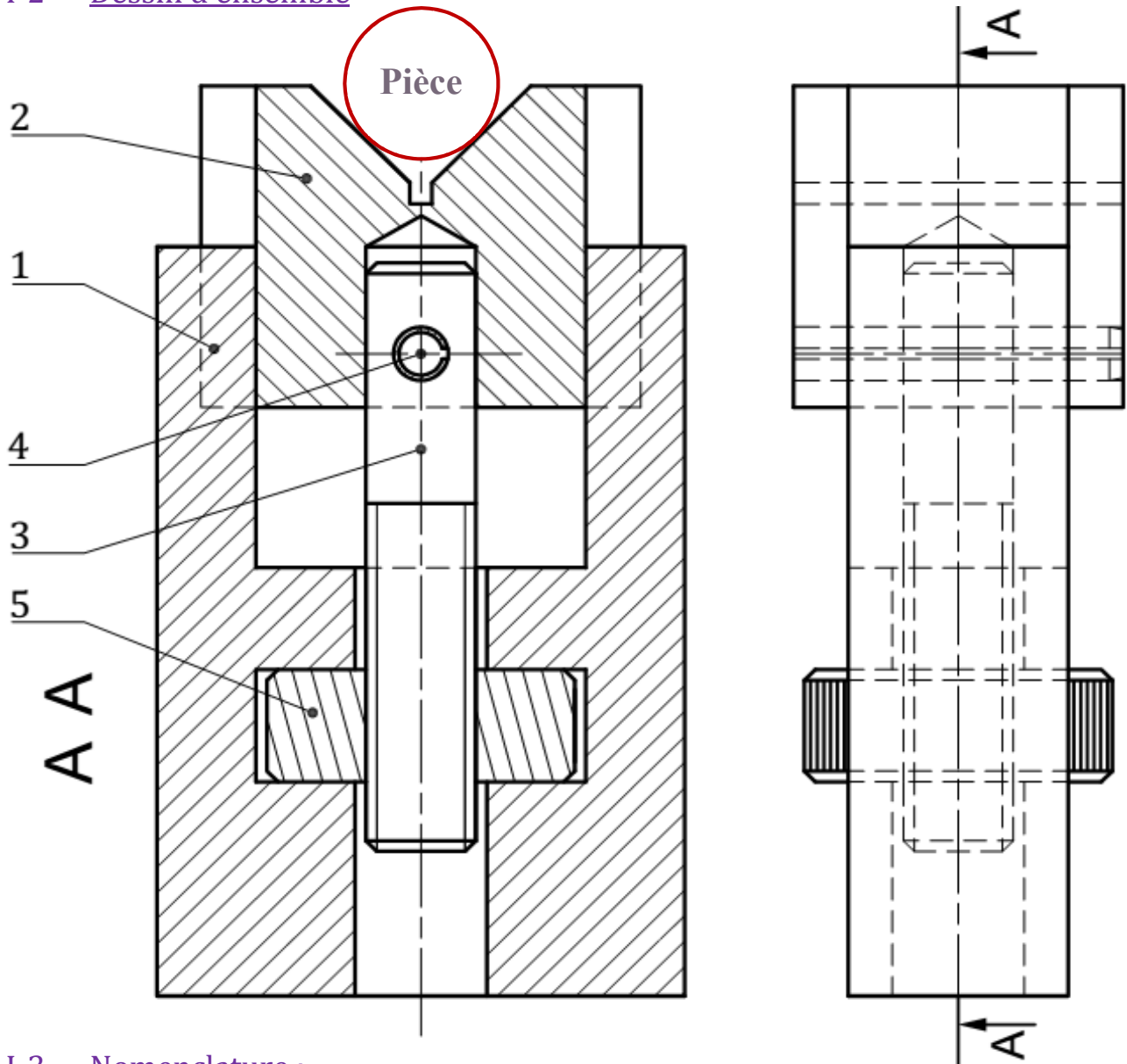

I-3 Nomenclature :

2	Coulisseau en Vé	4	Goupille élastique		
1	Corps	3	Tige filetée	5	Ecrou moleté
Rep	Nom	Rep	Nom	Rep	Nom

I-4 Modèle 3d

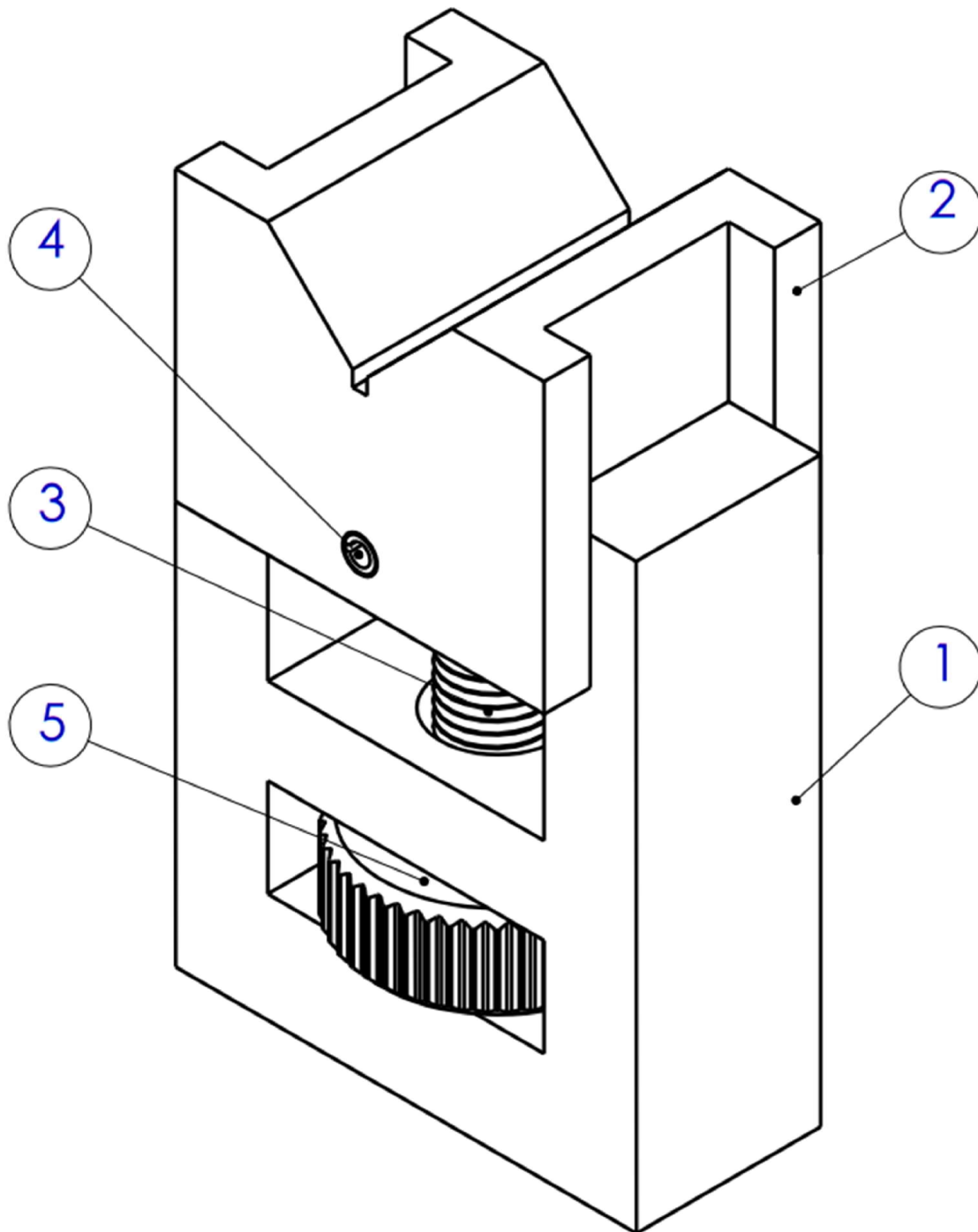

I-5 Fonctionnement:

La rotation de l'écrou moleté 5 autour de l'axe Z provoque la translation du coulisseau 2 suivant l'axe Z

I-6 Dessin d'ensemble éclaté

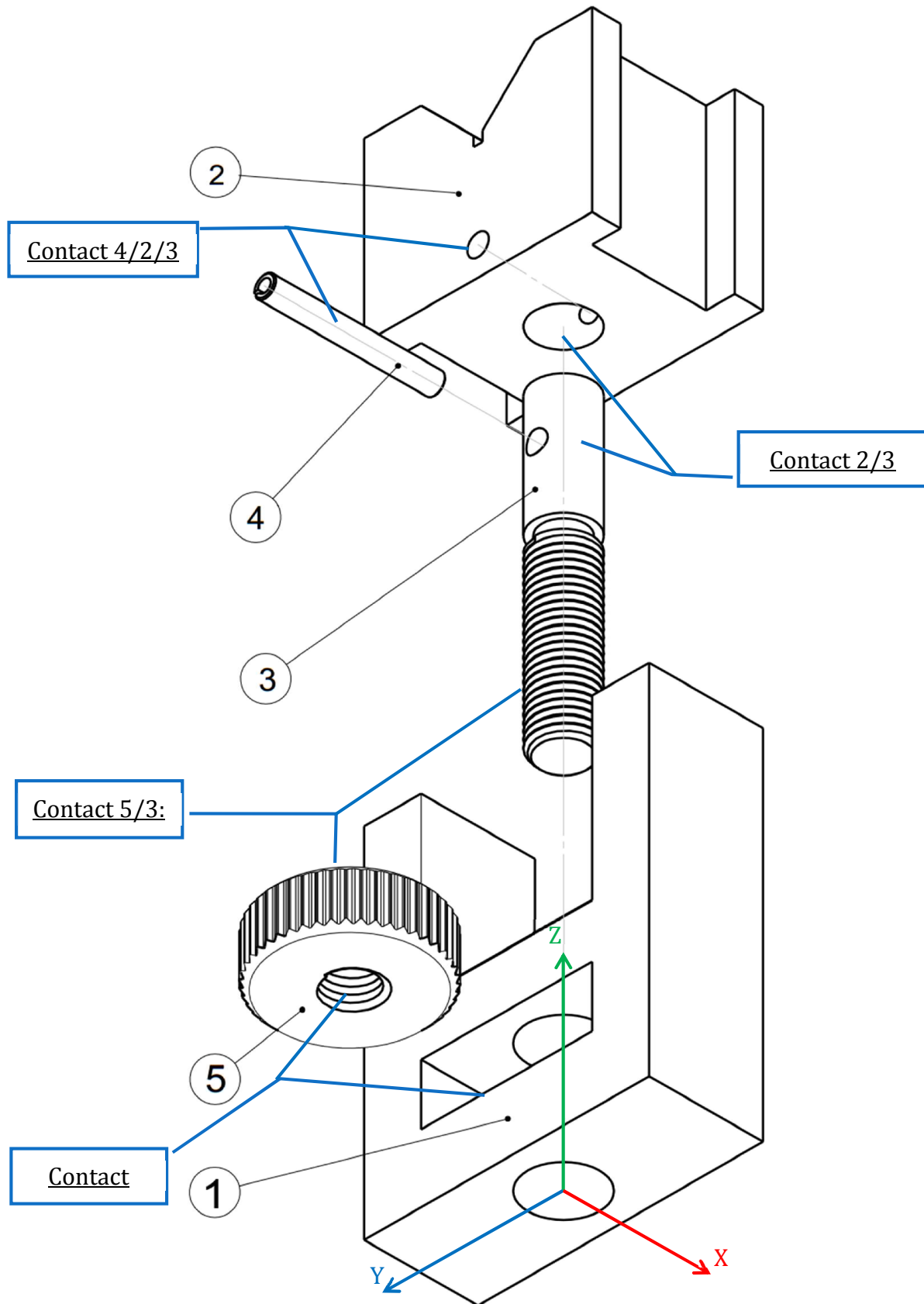

.II Liaisons

II-1 Définition :

Une liaison est une relation de contact entre deux pièces.



II-2 Degrés de liberté

Un solide libre dans l'espace possède 6 mouvements possibles par rapport à un repère R(X,Y,Z) appelés degrés de liberté

3 Rotations :

-  Rx
-  Ry
-  Rz

3 Translations :

-  Tx
-  Ty
-  Tz

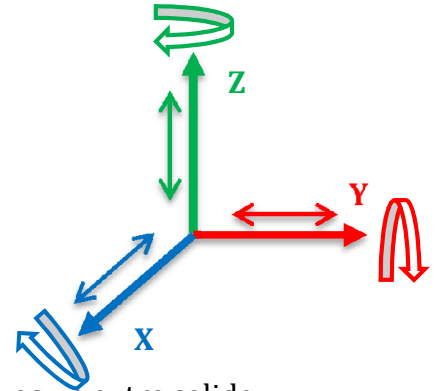

II-3 Degrés de liaison

Ce sont les degrés de liberté éliminés par une relation de contact avec un autre solide.

La nature des surfaces de contact détermine les mouvements relatifs

II-4 Application











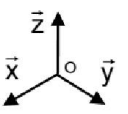
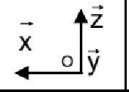
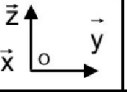
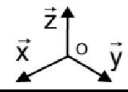
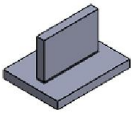



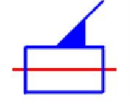
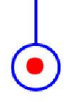
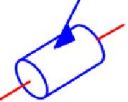

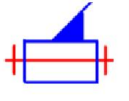
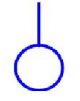
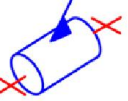

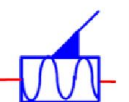
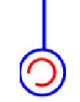
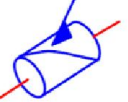







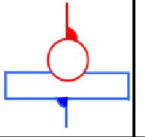

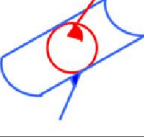
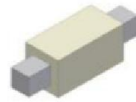
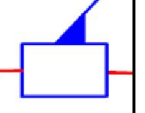
En se référant au dessin d'ensemble, au model 3D et au dessin éclaté, Compléter le tableau des liaisons suivant :

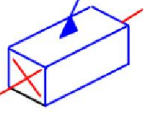
Pièces	Surfaces de contact	Degrés de liberté			Liaison	Symbole
		X	Y	Z		
1/2	Surfaces planes S1, S2	T			Glissière	
		R				
3/2	Surface cylindrique	T				
		R				
3/2/4	Surfaces cylindriques	T				
		R				
3/5	Surface hélicoïdale	T				
		R				
1/5	Surface plane	T				
		R				

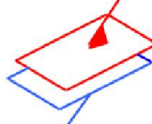
II-5 Classe d'équivalence

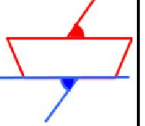
C'est un groupe de pièces liées ensemble par liaison encastrement : EX : {3,2,4}

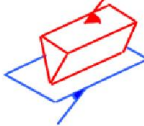
II-6 Liaisons usuelles

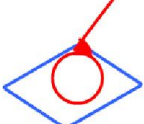
	Géométrie du contact	Degrés de liberté			Nom de la liaison	Symbole normalisé		
		T	R					
								
	Surfacique cylindrique			2				
	Surfacique cylindrique + Surfacique plan			1				
	Hélicoïdale			1				
	Surfacique sphérique			3				
	Surfacique sphérique + linéique rectiligne			2				
	Linéique annulaire			4				
	Plusieurs surfaciques plans			1				
	Surfacique plan			3				
	Linéique rectiligne			4				
	Ponctuel			5				

.III Schéma cinématique

III-1 Définition :

C'est une représentation simplifiée du mécanisme qui décrit fidèlement son fonctionnement

III-2 Graphe des liaisons

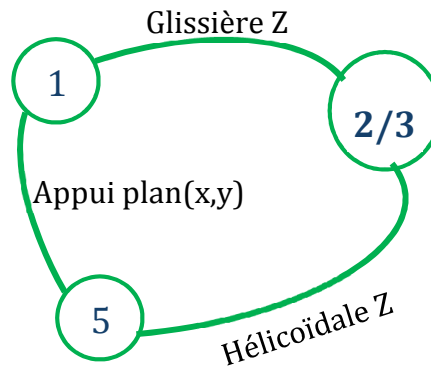

III-3 Schéma cinématique

